

# Technical Data for **SFF-Series** Mass Flow Controllers

## 10 SCCM full scale through 20 SLPM full scale



+1 (888) 290-6060  
 alicat.com/sff

SENSOR AND CONTROL PERFORMANCE	
Mass flow accuracy <sup>1</sup>	Standard accuracy: $\pm(0.8\%$ of reading + 0.2% of full scale) High-accuracy option: $\pm(0.4\%$ of reading + 0.2% of full scale)
Pressure accuracy <sup>2</sup>	Above 1 atm: $\pm 0.5\%$ of reading Below 1 atm: $\pm 0.07$ PSIA
Flow repeatability (2 $\sigma$ )	$\pm(0.1\%$ of reading + 0.02% of full scale)
Steady state control range	0.01–100% of full scale (10,000:1 turndown ratio)
Operating pressure full scale	11.5–160 PSIA
Pressure sensitivity	Mass flow zero shift: $\pm 0.01\%$ of full scale per atm from tare pressure Mass flow span shift: $\pm 0.1\%$ of reading per atm from calibration conditions
Temperature sensitivity	Mass flow zero shift: $\pm 0.01\%$ of full scale per °C from tare temperature Mass flow span shift: $\pm 0.01\%$ of reading per °C from 25°C
Temperature accuracy	$\pm 0.75^\circ\text{C}$
Operating temperature range	-10–60°C (ambient and gas)
Valve function	Normally closed
Totalizer volume uncertainty	$\pm 0.1\%$ of reading in in additional uncertainty
Sensor response time	<1 ms
Typical control response time	As fast as 30 ms, flow rate dependent, user-adjustable
Typical indication response time	<10 ms, flow rate dependent
Typical warm-up time	<1 s

**1** Stated accuracy is after tare under equilibrium conditions, includes repeatability and linearity.

**2** Under equilibrium conditions. Includes repeatability and linearity.

MECHANICAL	
Wetted materials	302, 303, 304, 316L, and 430FR stainless steel; FKM, alumina ceramic, brass, glass, gold, heat-cured epoxy, heat-cured silicone rubber, polyamide, silicon
Maximum pressure	Damage possible above 200 PSIA common mode pressure. Damage possible by rapid pressure change above 75 PSI differential pressure.
Relative humidity range	0–95%, non-condensing
Ingress protection	IP40
Leak integrity, external	$<1 \times 10^{-9}$ atm-cc/sec of helium
Leak integrity, through closed valve	$<1 \times 10^{-5}$ atm-cc/sec of helium at zero set point
Mounting orientation sensitivity	None
Mounting holes	2 $\times$ 8-32 UNC threaded, $\bar{J}$ . 250"[6.35mm]
Process connections	$\frac{1}{4}$ " VCR®-compatible male

POWER AND COMMUNICATIONS	
Digital input and output options	RS-232 Serial and Modbus RTU (default), RS-485 Serial and Modbus RTU, Modbus TCP/IP, DeviceNet, EtherCAT, EtherNet/IP, PROFINET, PROFIBUS
Digital data update rate <sup>3</sup>	40 Hz at 19200 baud
Analog input and output options	4–20 mA, 0–5 Vdc, 1–5 Vdc, 0–10 Vdc
Analog data update rate <sup>3</sup>	1 kHz
Analog signal accuracy	$\pm 0.1\%$ of full scale additional uncertainty
Interactive display	Monochrome LCD or color TFT display with integrated touchpad; simultaneously displays mass flow, volumetric flow, temperature, setpoint, and pressure.
Display update rate	10 Hz
Electrical connection options	6-pin locking, 8-pin mini-DIN, 8-pin M12, 9-pin DB-9, 15-pin DB-15 (Contact Alicat for custom pinouts)
Power requirements <sup>3</sup>	12–24 Vdc, 250 mA (290 mA if equipped with 4–20 mA output)

**3** Consult the individual operating bulletins for specific industrial protocol power requirements and data transmission specifications.

# Technical Data for SFF-Series Mass Flow Controllers

## 10 SCCM full scale through 20 SLPM full scale



+1 (888) 290-6060  
 alicat.com/sff

FEATURES	
SFF standard length	Matches 124 mm end-to-end length of SFF standard MFCs
STP reference conditions	25°C and 1 atm (default), user-configurable
NTP reference conditions	0°C and 1 atm (default), user-configurable
Gas Select™	98 user-selectable gases stored internally. Each gas optimized to match NIST's REFPROP 10 gas property calculations across the operating temperature and pressure ranges for highest accuracy.

RANGE-SPECIFIC TECHNICAL DATA	
Full scale flow	Pressure drop when venting to atmosphere <sup>4</sup>
10-50 SCCM	1.0 PSID
1 SLPM	1.5 PSID
2 SLPM	3.0 PSID
5 SLPM	2.0 PSID
10 SLPM	5.5 PSID
20 SLPM	20.0 PSID

<sup>4</sup> Default valve venting air to atmosphere. Other valves may be available.

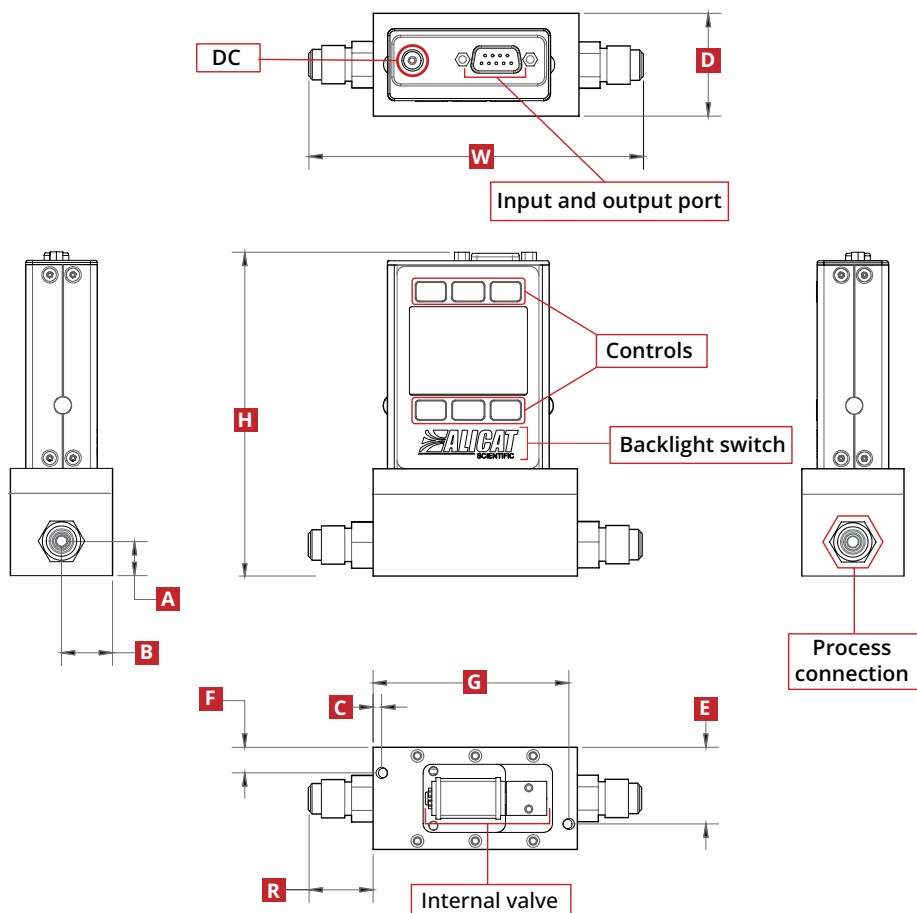

### Representative Example

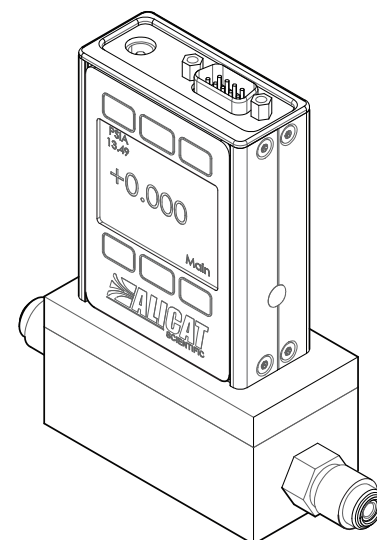

Full scale flow	DIMENSIONS										WEIGHT
	Height	Width	Depth	A	B	C	E	F	G	R	
10 SCCM– 20 SLPM	4.76"	4.88"	1.50"	0.50"	0.75"	0.16"	1.13"	0.38"	2.88"	0.94"	≈ 2.0lb
	120.8 mm	124.0 mm	38.1 mm	12.7 mm	19.1 mm	4.1 mm	28.6 mm	9.5 mm	73.0 mm	23.9 mm	≈ 1.0 kg