

8 7 6 5 4 3 2 1

D

C

B

A

D

C

B

A

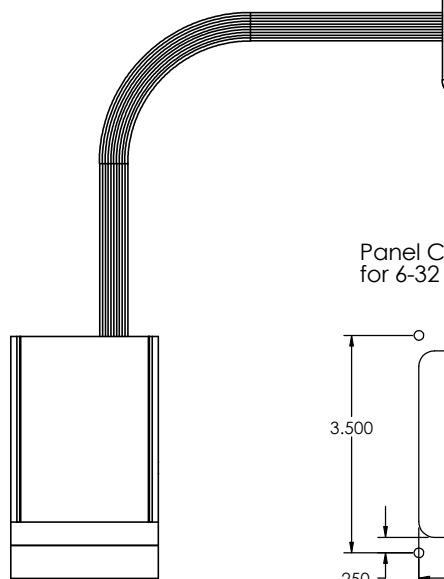
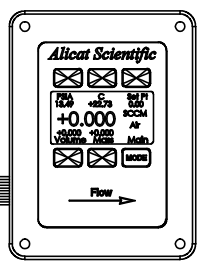
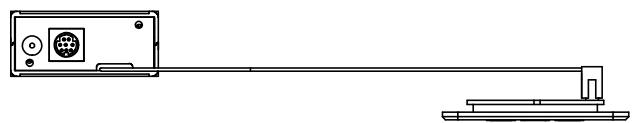

Panel Cut Out Template
for 6-32 Screws and Nuts

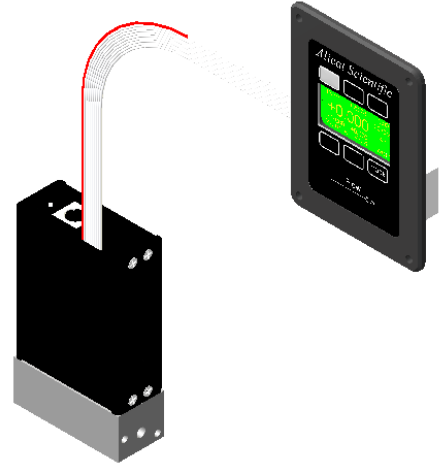
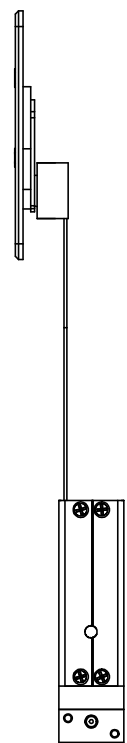
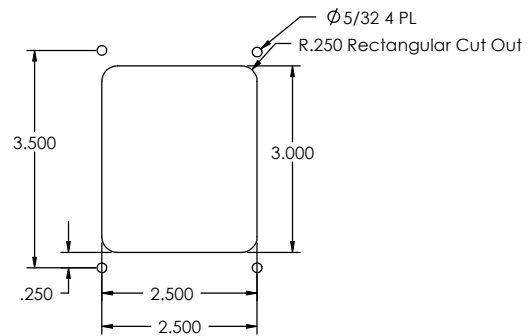

Rev. No.	Description	Date

- Notes:
1. Break all sharp edges .005/.015 x 45 Deg. Radius optional.
 2. Transport as to prevent damage
 3. No nicks or dings allowed on machined surfaces.
 4. Remove all burrs

PROPRIETARY AND CONFIDENTIAL
THE INFORMATION CONTAINED IN THIS DRAWING IS THE SOLE PROPERTY OF ALICAT SCIENTIFIC, INC. ANY REPRODUCTION IN PART OR AS A WHOLE WITHOUT THE WRITTEN PERMISSION OF ALICAT SCIENTIFIC, INC. IS PROHIBITED.

DATE **5/26/2009**
MATERIAL ---
FINISH ---
DO NOT SCALE DRAWING

DIMENSIONS ARE IN INCHES
TOLERANCES:
ANGULAR: 20° 30'
THREE PLACE DECIMAL ±.005
FOUR PLACE DECIMAL ±.0005

Checked by ---
Alicat Scientific, Inc.
2045 N. Forbes Blvd. Suite 103 Tucson, AZ 85745
520-290-6060 Ph. 520-290-0109 Fax
REV. **X**

8 7 6 5 4 3 2 1