



SAFETY AND INSTALLATION MANUAL FOR IS-MAX AND IS-PRO INTRINSICALLY SAFE DEVICES

DOC-MANUAL-IS-SAFEINSTALLATION

This manual contains information for safe installation and use of IS-Max and IS-Pro intrinsically safe devices. All operators must read this manual in completion before attempting to install or operate the device.

Thank you for purchasing your Alicat Device.

If you have any questions, or if something is not working as expected, please contact us. We are eager to help you in any way possible.

Contact Information

Manufacturing:
World Headquarters,
Tucson, Arizona, USA
info@alicat.com
alicat.com
7641 N Business Park Dr.,
Tucson, AZ 85743 USA
+1 888-290-6060

China & SE Asia service and support
info-cn@alicat.com
alicat.com.cn
+86 21-6151-9020

Europe service and support
europa@alicat.com
+31 (0)26 203.1651

India service and support
india@alicat.com
+91 022-41248010

Recalibrate your device every year.

Annual calibration is necessary to ensure the continued accuracy of readings, and to extend the Limited Lifetime Warranty. Fill out the Service Request Form at alicat.com/service, or contact us directly when it is time to send in your device for recalibration.

Lifetime Warranty

For information about our limited lifetime warranty, visit alicat.com/warranty.

European Directive Information

Alicat IS-Pro and IS-Max instruments with model designations beginning with the letters "IS" are intrinsically safe devices which comply with ATEX Directive 2014/34/EU, Electromagnetic Compatibility directive 2014/108/EU, and ROHS directive EU 2015/863.

They have been designed and evaluated according to EN IEC 60079-0:2018, EN 60079-11:2012, EN 61326-1:2013, and EN IEC 63000:2018.

These instruments are excluded from Pressure Equipment Directive (PED)2014/68/EU by complying with the ATEX directive and being categorized no higher than PED equipment category I.

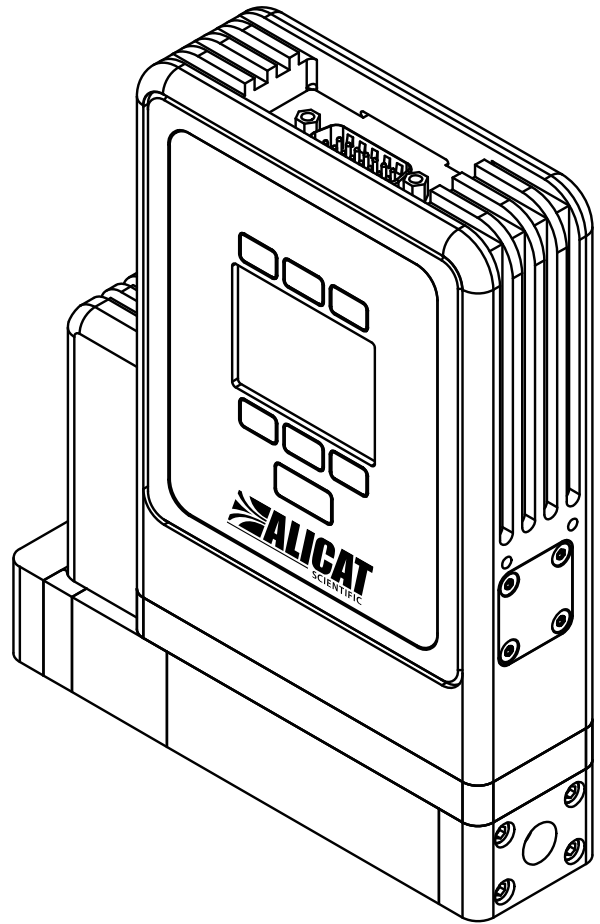

Approvals and certificate numbers:



0344

DEKRA 22ATEX0075 X

IECEx DEK 22.0078 X



II 1 G Ex ia IIC T4 Ga

Ex ia IIC T4 Ga

T_{amb} -20°C to +70°C

Legal Information

Warning Symbols

The contents of this manual outline the safe and verified installation and use of the Alicat device. Throughout are various warnings marked by a warning symbol. These warnings must be observed to ensure safe operation of the device for both person and property. Failure to do so may result in the device failing to function properly and may cause an unsafe environment.



All notices marked by this symbol must be read and understood before installation and operation of the device. These warnings provide information about potential dangers of improper use of the device.

Device Use

This device may only be installed and used as indicated by this manual. Any use outside of the operational scope of the device may result in an unsafe operational environment. The allowed ambient conditions must be followed. These conditions can be found within the manual.

Qualified Personnel

Only personnel that have read this manual, all its safety warnings, and are identified as a competent body by the methods of protection Ex i may install or operate this device. Should the device fail in any way, do not attempt to repair it

in the field. Only Alicat certified operators may attempt to repair it. Attempts to open the device or perform unauthorized maintenance will create an unsafe environment for use and void any warranty.

Disclaimer

While this manual and device operation is extensively and regularly reviewed both by Alicat and its certifying body, not all possible permutations of issues can be accounted for. The information within this document accounts for known and tested issues that have been identified. Revisions of this document will contain any new warnings to be determined as necessary and can be found at alicat.com/manuals.

Contents

Legal Information	3
Warning Symbols	3
Device Use	3
Qualified Personnel	3
Disclaimer	3
Important Safety Warnings	5
English	5
Français	5
Device Installation and Removal	6
Installation	6
Removal	7
Terminology	8
Control Drawing	9
General Notes	9
Specific Conditions for Safe Use (x)	9
Table 01 - Summary of Individual Entity Parameters	10
Figure 01 Connection to Approved Barriers	11
Individual Entity Parameters Notes	12
Applications Examples	13
Galvanically Isolated Serial RS485	15
Non-Galvanically Isolated Serial	16
Non-Galvanically Isolated Valve Barrier and Non-Galvanically Isolated Serial Barrier	17
Shared Isolated Barrier for Main Power	18
Shared Non-Isolated Barrier for Main Power	19
Single Isolated Barrier for Power	20
Cable and Connector Pinout	21
Pinouts	21
Maintenance	22
Cleaning	22
Repair	22
Recalibration	22
Troubleshooting	22
General Use	22

Important Safety Warnings

English



Read all instructions before operation. Any personnel that operates or installs this instrument must be trained and qualified.



Before installing, confirm that the intended process flow rates and pressures are within the specifications of your device. Operating this device under conditions that exceed the specifications could lead to equipment damage or personal injury.



It is the responsibility of qualified personnel to confirm compatibility between the wetted materials of the device and the process media before installation. Use of this device with incompatible media could cause property damage, injury, or death.



Do not disassemble the device. This device can only be serviced by authorized Alicat personnel.



Depending on the model, this device is capable of measuring hazardous gases such as acetylene and carbon monoxide. Mishandling of these gases may create a risk of fire, explosion, asphyxiation, or poisoning, even if used within the ratings of the device. The safety of any system incorporating this equipment is the responsibility of the assembler of that system. Ensure that appropriate ventilation and monitoring systems are in place to protect personnel and equipment. Always leak-check any system intended to contain a hazardous gas or fluid before operation.



Do not attempt to disconnect this device from any system which has been pressurized without independently confirming that all pressure has been safely released and that any hazardous gases which remain in that system have been purged.



The process fluid must not exceed the -20°C to +70°C environmental temperature limits.

If you have any questions or concerns about the proper and safe use of your device, please contact Alicat support ([page 2](#)).

Français



Lisez toutes les instructions avant utilisation. Le personnel qui utilise ou installe cet instrument doit être formé et qualifié.



Avant l'installation, confirmez que les débits et la pression prévus du procédé sont conformes aux spécifications de votre appareil. L'utilisation de cet appareil dans des conditions qui dépassent les spécifications indiquées dans ce manuel ou la fiche technique peut entraîner des dommages matériels ou des blessures.



Il est de la responsabilité du personnel qualifié de confirmer la compatibilité entre les matériaux mouillés de l'appareil et le fluide de procédé avant l'installation. L'utilisation de cet appareil avec des supports incompatibles peut entraîner des dommages matériels, des blessures ou la mort.



Ne démontez pas cet appareil. L'entretien de cet appareil peut uniquement être effectué par un personnel d'Alicat autorisé.



Selon le modèle Cet appareil peut mesurer des gaz dangereux tels que l'acétylène et le monoxyde de carbone. Une mauvaise manipulation de ces gaz peut créer un risque d'incendie, d'explosion, d'asphyxie ou d'empoisonnement, même s'ils sont utilisés dans les caractéristiques nominales de l'appareil. La sécurité de tout système incorporant cet équipement relève de la responsabilité de l'assembleur de ce système. Assurez-vous que des systèmes de ventilation et de surveillance appropriés soient en place afin de protéger le personnel et l'équipement. Avant utilisation, vérifiez toujours les fuites de n'importe quel circuit destiné à contenir un gaz dangereux.



N'essayez pas de déconnecter cet appareil d'un circuit qui a été pressurisé sans confirmer de manière indépendante que toute la pression ait été libérée en toute sécurité et que tous les gaz dangereux restant dans ce circuit aient été purgés.

Si vous avez des questions ou des préoccupations concernant l'utilisation correcte et sûre de votre appareil, veuillez contacter le support Alicat ([page 2](#)).

Device Installation and Removal

Installation

Before installing, refer to the control drawing ([page 9](#)) for connection setup, device pinout, and cabling to ensure all electrical connections comply with barrier and safety requirements.

The device does not require straight runs of pipes either upstream or downstream of the device. It can operate in any orientation whether it's on its side, laid on its back, or inverted and operating upside down. Be sure to reference your device dimensions ([page 23](#)) to determine the size and positions of the mounting holes on the bottom of the device.



Do not install the device in direct sunlight.

Filters upstream of the device are recommended to ensure no particulates or biological matter enter the flow body or valve.

1. Mount the device so that flow will pass through the flow body as indicated by the arrow on the front of the device (left to right by default). See the appendices on [page 23](#) for your device's mounting specifications.
2. Remove the plastic plugs from the inlet and outlet connections (and process connection, if present).
3. Plumb appropriate lines to the inlet and outlet connections (and process connection, if present). Face seal fittings do not need Teflon tape applied to the threads.



Do not use pipe dopes or sealants on the process connections. These compounds can cause permanent damage to the device should they get into the flow stream.

If you are using a fitting that does not have a face seal, use thread-sealing Teflon tape to prevent leakage around the connections.



Do not wrap the first two threads entering the device. This minimizes the possibility of getting tape into the flow stream and clogging or damaging the device.

4. Wire the cable to the barrier as per the appropriate control drawing.
5. Connect the supplied cable to the power and signal connector.
6. Enable power to the device. The device automatically turns on once the device is connected to power.



Do not enable power to the device until all necessary pins have been confirmed to be properly connected.

The device is now ready for use. Please refer to the **Operations Manual for IS-Max and IS-Pro Intrinsically Safe Devices** for operation instructions. The manual can be found at alicat.com/manuals.

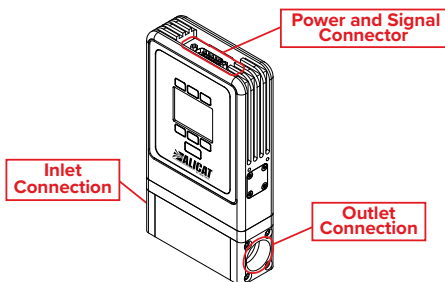
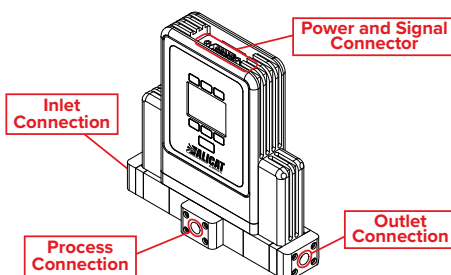
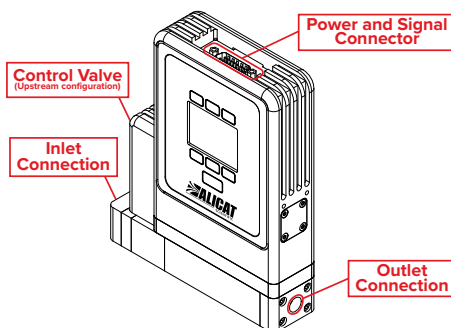
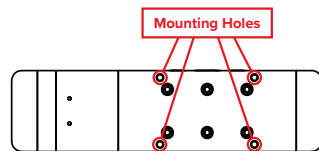
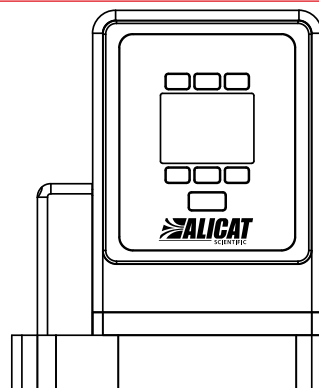

Removal

When a device is being removed from the process line, follow these steps:

1. Purge the lines of any hazardous gases or liquids.
2. Reduce the line pressure to safe levels.
3. Disconnect power to the device and allow the device to fully power off.
4. Disconnect the cable from the power and signal connector.
5. Disconnect the lines from the inlet and outlet connections (and process connection, if present).
6. Return the plastic plugs to the inlet and outlet connections (and process connection, if present).

The device can now be removed.



Do not disconnect the cable from the power and signal connector until it has been confirmed that there is no power running to the device on any of its possible power connections.

Terminology

The following is a list of definitions from IEC60079-11 Edition 6, section 3.13. Please refer to these definitions when using the control drawings and table.

Associated Apparatus

Electrical equipment which contains both intrinsically safe circuits and non-intrinsically safe circuits and is constructed so that the non-intrinsically safe circuits cannot adversely affect the intrinsically safe circuits. Associated apparatus may be either:

- Electrical equipment which has another type of protection listed in IEC 60079-0 for use in the appropriate explosive atmosphere, or
- Electrical equipment not so protected and which, therefore, is not normally used within an explosive atmosphere. For example, a recorder which is not itself in an explosive atmosphere but is connected to a thermocouple situated within an explosive atmosphere where only the recorder input circuit is intrinsically safe.

Entity Parameters:

The lower case “i” suffix refers to external signal characteristics that can be applied to a device from another device (or is allowed to be applied), and the “o” suffix refers to the maximum output characteristics from a device. Thus, X_o from one device must be $\leq X_i$ at the other device.

Maximum input voltage (U_i): Maximum voltage (peak a.c. or d.c.) that can be applied to the connection facilities of apparatus without invalidating the type of protection.

Maximum input current (I_i): Maximum current (peak a.c. or d.c.) that can be applied to the connection facilities of apparatus without invalidating the type of protection.

Maximum input power (P_i): Maximum power that can be applied to the connection facilities of apparatus without invalidating the type of protection.

Maximum internal capacitance (C_i): Maximum equivalent internal capacitance of the apparatus which is considered as appearing across the connection facilities.

Maximum internal inductance (L_i): Maximum equivalent internal inductance of the apparatus which is considered as appearing at the connection facilities.

Maximum internal inductance to resistance ratio (L_i/R_i): Maximum value of ratio of inductance to resistance which is considered as appearing at the external connection facilities of the electrical apparatus.

Maximum output voltage (U_o): Maximum voltage (peak a.c. or d.c.) that can appear at the connection facilities of the apparatus at any applied voltage up to the maximum voltage.

Maximum output current (I_o): Maximum current (peak a.c. or d.c.) in apparatus that can be taken from the connection facilities of the apparatus.

Maximum output power (P_o): Maximum electrical power that can be taken from the apparatus

Maximum external capacitance (C_o): Maximum capacitance that can be connected to the connection facilities of the apparatus without invalidating the type of protection.

Maximum external inductance (L_o): Maximum value of inductance that can be connected to the connection facilities of the apparatus without invalidating the type of protection.

Maximum external inductance to resistance ratio (L_o/R_o): Maximum value of ratio of inductance to resistance that can be connected to the external connection facilities of the electrical apparatus without invalidating intrinsic safety

Maximum r.m.s. a.c. or d.c. voltage (U_m): Maximum voltage that can be applied to the non intrinsically safe connection facilities of associated apparatus without invalidating the type of protection

Control Drawing

General Notes

1. Control equipment connected to the barrier must not use nor generate more than 250v.
2. Approved barriers must be installed in accordance with the manufacturer's instructions.
3. This implementation utilizes a cable containing more than one intrinsically safe circuit (ref. IEC 60079-25 8.3). Use only Alicat specified cable. The Alicat specified cable is in accordance with the requirements of a multi-circuit cable type A or type B, as specified in IEC 60079-14. The Alicat supplied cable is constructed with solid insulation per IEC 60079-11 Edition 6 Table 5, for <30V, where appropriate separation is applied in order to facilitate certification with multiple intrinsically safe circuits in one cable.
4. **The Alicat supplied cable follows the maximum entity values of 550pF/meter, 1μH/meter and 5.3μH/Ω.** Where a barrier omits a parameter, that parameter is not required. For example, a certain IS power supply certificate states a maximum value for L/R without stating L. This means that only L/R needs to be considered and an equivalent L value need not be assumed or inferred. Likewise, another IS power supply certificate states L without stating L/R. In this case an equivalent L/R value need not be assumed or inferred.
5. All signal returns are connected together internal to the IS-Max or IS-Pro. The internal connections are isolated from the chassis. As a result, external voltages do not need to be summed.
6. All wiring must run separately in the Alicat supplied cable and terminated at the barrier(s). Modification of the cable (other than length) is not permitted.
7. Non-galvanically isolated barriers must be co-located and must terminate safety grounds to the same physical earthing connection or grounding rod. Separated grounds are not permitted.
8. Where galvanically non-isolated barriers are used, the installer must consider that return current may be summed for all non-isolated barriers (ref. IEC 60079-25 Annex B). The sum of the currents for 2 or more non-galvanically isolated barriers cannot exceed IEC 60079-11 Table A.2 at the voltage for the higher or highest of the barriers in use. This is the responsibility of the installer to involve personnel skilled in making the assessment. (REF IEC 60079-14 A.2)
9. Install per EN 60079-14, IEC 60079-14, ANSI/ISA-RP12.6, ANSI/NFPA 70, CSA C22.1, and all local installation codes (as applicable).
10. The user is permitted to utilize the summary of individual entity parameters in Table 01 of this document to interpret additional configurations of barriers not shown in the example configurations. The entity concept must be followed. This is the responsibility of the installer to involve personnel skilled in making the assessment (ref IEC 60079-14 A.2).



Warning: substitution of components may impair intrinsic safety.

Avertissement: la substitution de composants peut compromettre la sécurité intrinsèque.



Warning: explosion hazard – do not disconnect equipment unless primary power has been switched off or the area is known to be non-hazardous.

Avertissement : risque d'explosion - ne déconnectez pas l'équipement à moins que l'alimentation principale n'ait été coupée ou que la zone ne soit connue comme étant non dangereuse.

Specific Conditions for Safe Use (x)

- The black metal sections of the enclosure are anodized aluminum and are a potential impact ignition source. Protect the apparatus from impact and abrasion as appropriate for the installation zone.

SIGNAL NAME	SIGNAL FUNCTION	CIRCUIT ON CONTROL DIAGRAM	IS-Max or IS-Pro CONNECTOR PIN	SIGNAL RETURN	U _i /V _{max}	P _i	I _i	C _i	L _i	U _o /V _{oc}	P _o	I _o /I _{sc}	C _o	L _o					
MAIN POWER IN	MAIN MODULE POWER INPUT	A	10	9	12.1V	INTERNALLY LIMITED	3.33A	0	0	N/A - BLOCKED WITH INFALLIBLE SERIES DIODES -★									
					13V		2.02A												
					14V		1.2A												
					15V		0.9A												
					15-28V		0.12A												
VALVE POWER IN	VALVE MODULE POWER INPUT	B	1	2	12.1V	INTERNALLY LIMITED	3.33A	0	0	N/A - BLOCKED WITH INFALLIBLE SERIES DIODES -★									
					13V		2.02A												
					14V		1.2A												
					15V		0.9A												
					15-28V		0.12A												
RS232RX, TX OR RS485A, B	SERIAL INTERFACE with respect to signal return	C*	8 & 15 together wrt return	13	28V	0.4W	0.12A	0	0	6.44V	490mW	656mA	25µF	68µH					
					15V		0.9A				285mW	177mA		1.135mH					
RS485A, B	SERIAL INTERFACE to isolated barrier	C♦	8 wrt 15 or 15 wrt 8	none (isolated barrier)	28V	0.4W	0.12A	0	0										
					15V		0.9A												
REMOTE TARE	DISCRETE SWITCH INPUT (GND ACTIVE)	D	14	11	28V	N/A - BLOCKED WITH INFALLIBLE SERIES DIODES -													
AUX DISCRETE 01			4													16mW	1mA	6.25µF	2.22H
AUX DISCRETE 02			3													16mW	1mA	6.25µF	
ANALOG SIGNAL IN	4-20mA, 0-5 OR 0-10V INPUT	E	12	11	28V	0.651W	93mA	0	0	6.44V	4mW	<1mA	6.5µF	2.22H					
4-20mA POWER IN	4-20mA POWER INPUT	F	6	5	28V	0.651W	93mA	0	0	N/A - BLOCKED WITH INFALLIBLE SERIES DIODES - ★	0.651W	94mA	0.069µF	4.0239mH					
4-20mA SIGNAL OUT	4-20mA SIGNAL OUTPUT	F	7	5	28V	N/A - BLOCKED WITH INFALLIBLE SERIES DIODES													

* Each instrument is configured exclusively for RS232 or RS485 by internal jumpers. Use these parameters when using a barrier that is referenced to signal return.
♦ Use these parameters for RS485 with a 2-wire an isolated barrier that is not referenced to signal return.
★ N/A - BLOCKED WITH INFALLIBLE SERIES DIODES: Three suitably rated series diodes are used internal to the device to only allow current in one direction and block all current in the other direction. In the case of an output, this means there is no U_p, P_p, I_p, C_p, or L_p. In the case of an input, this means there is no U_o, P_o, I_o, C_o, or L_o.

TABLE 01 - SUMMARY OF INDIVIDUAL ENTITY PARAMETERS

THE USER IS PERMITTED TO UTILIZE THE SUMMARY OF INDIVIDUAL ENTITY PARAMETERS IN TABLE 05 OF THIS DOCUMENT TO INTERPRET ADDITIONAL CONFIGURATIONS OF BARRIERS NOT SHOWN IN THE EXAMPLE CONFIGURATIONS. THE ENTITY CONCEPT MUST BE FOLLOWED. THIS IS THE RESPONSIBILITY OF THE INSTALLER TO INVOLVE PERSONNEL SKILLED IN MAKING THE ASSESSMENT. (REF IEC 60079-14 A.2)

HAZARDOUS LOCATION
 Class I, Zone 0, Group IIC, T4
 Class I, Div. 1, Group A,B,C,D,T4
 Ta -20°C to +70°C

NON-HAZARDOUS LOCATION OR RATED LOCATION
 (Installer must observe barrier manufacturer's instructions, equipment markings and special conditions for all devices)

APPROVED BARRIERS

ALICAT IS-Max or IS-Pro

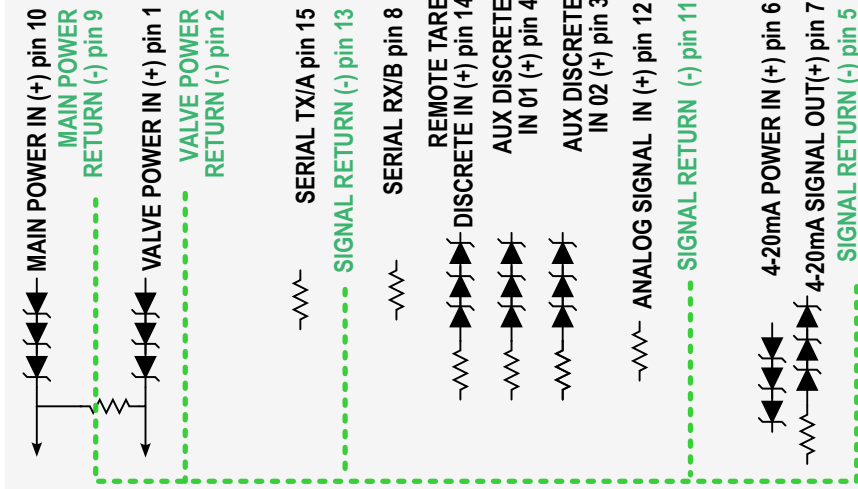

NOTE: ALL POWER AND SIGNAL RETURNS ARE CONNECTED TOGETHER INTERNAL TO DEVICE AND ISOLATED FROM CHASSIS.

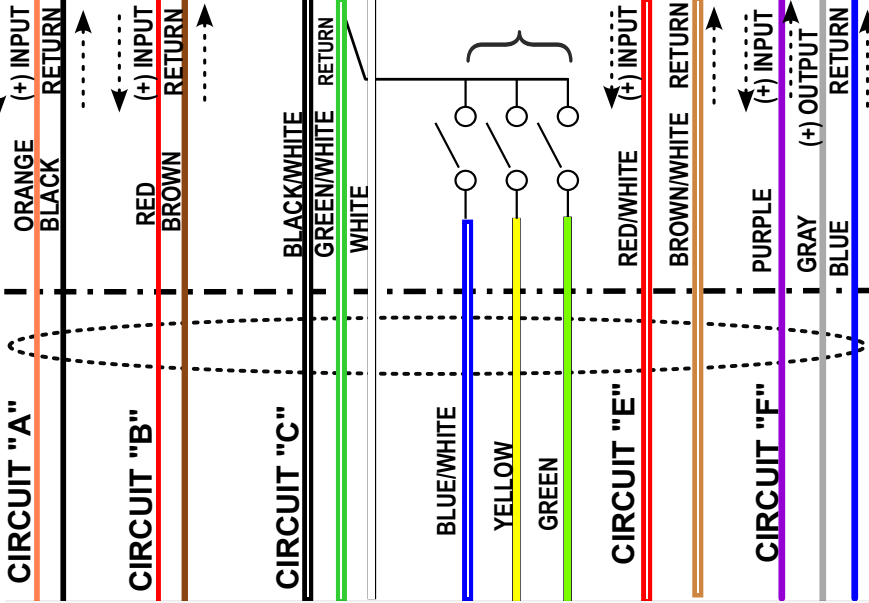

USE ENTITY PARAMETERS FROM CONTROL DRAWING TABLE 01 CIRCUIT "A" + CABLE PARAMETERS IN NOTE 4

USE ENTITY PARAMETERS FROM CONTROL DRAWING TABLE 01 CIRCUIT "B" + CABLE PARAMETERS IN NOTE 4 (NOT CONNECTED FOR METER ONLY APPLICATION)

USE ENTITY PARAMETERS FROM CONTROL DRAWING TABLE 01 CIRCUIT "C" + CABLE PARAMETERS IN NOTE 4 (RETURN NOT USED FOR ISOLATED RS485)

USE ENTITY PARAMETERS FROM CONTROL DRAWING TABLE 01 CIRCUIT "D" + CABLE PARAMETERS IN NOTE 4

USE ENTITY PARAMETERS FROM CONTROL DRAWING TABLE 01 CIRCUIT "E" + CABLE PARAMETERS NOTE 4

USE ENTITY PARAMETERS FROM CONTROL DRAWING TABLE 01 CIRCUIT "F" + CABLE PARAMETERS NOTE 4

ALICAT SUPPLIED PRE-FABRICATED MOULDED CABLE
 550pF/meter
 1.0µH/meter
 5.3µH/Ω max.



FIGURE 01 CONNECTION TO APPROVED BARRIERS

Individual Entity Parameters Notes

- The IS-Max or IS-Pro design is such that the interfaces may be grouped into three (3) separate intrinsically safe circuits consisting of circuit A, circuit B, and the sum of the circuits C, D, E, and F. The separate circuits may also be combined where the associated barrier(s) fit within the entity parameter calculations.
- The entity parameters for the power connections are defined in Table 01, circuits A and B. Main power (Circuit A) is always necessary. Valve power (Circuit B) is optional in the case of a meter only device. Circuit A and circuit B are served by separate barriers or can be both supplied by a single barrier. For <15V, power is internally limited per the safety concept. For 15-28V, the barrier power is restricted to 1.25W per the safety concept.
- *12V maximum is recommended for best valve performance (not a safety requirement).*
- The entity parameters for the serial connections are defined in Table 01 circuit C. Each instrument is factory configured exclusively for RS232 or for RS485 by internal jumpers.
- When the barrier is RS485 and has no common return (isolated), the entity parameters only apply between the signal conductors and not to return.
- The entity parameters for the discrete input connections are defined in Table 01, circuit D. These signals are not required to be separate intrinsically safe circuits from any other circuit on the signal connector. Signals are activated by connection to return. This could be a simple switch contact or an intrinsically safe relay, or discrete output barrier. The signals are diode blocked and thus protected from an external Um. These signals may have entity parameters combined with other signals in the same device.
- Entity parameters for the analog input connection are defined in Table 01, circuit E. The 4-20mA/0-5V/0-10V input is software selected for voltage or current, however the selection does not affect the entity parameters.
- The 4-20mA power in/signal out circuit (circuit F) accepts power from a barrier (pin 6), provides diode isolation, adds 4-20mA control, and delivers the current back out on pin 7. For the evaluation of entity parameters, the output U_o/V_o , I_o/I_{sc} , P_o from pin 7 is \leq the entity parameters of the barrier connected to pin 6.

Applications Examples

The following information and drawings are intended to help the user select appropriate IS barriers and plan a new installation of Alicat IS devices.



Note: Always refer to the official Alicat Control Drawing and device certificate (Dekra) as well as the device certificates, control drawings and user manuals for all third party IS barriers that are used with the Alicat device. Alicat only provides this information as a reference. This information is not intended to be used by those not knowledgeable in safety.



The user must have a qualified understanding of the applicability of EN 60079-14, IEC 60079-14, and applicable local installation codes.

The Entity Concept allows interconnection of intrinsically safe apparatus with associated apparatus not specifically examined in combination as a system when the approved values of V_{oc} (or U_o), I_{sc} (or I_o) and P_o for the associated apparatus are less than or equal to $V_{max}(U_i)$ and $I_{max}(I_i)$ for the intrinsically safe apparatus and the approved values of C_a (C_o) and L_a (L_o) for the associated apparatus are greater than $C_i + C_{cable}$ and $L_i + L_{cable}$, respectively, for the intrinsically safe apparatus.

These parameters define the energy, whether continuous or stored and available for discharge, to make a spark. Voltage (U_o , U_i), current (I_o , I_i), power (P_o , P_i), inductance (L_o , L_i) and capacitance (C_o , C_i) are normal parameters.



Note: The reduced capacitance of the external circuit (including cable) shall not be greater than $1\mu F$ for C, D (IIB) and $600nF$ for A, B (IIC). Capacitance and inductance of the field wiring from the intrinsically safe equipment to the associated apparatus shall be calculated and must be included in the system calculations. Cable capacitance, C_{cable} , plus intrinsically safe equipment capacitance, C_i must be less than the marked capacitance, C_o (or C_o), shown on any associated apparatus used. The same applies for inductance (L_{cable} , L_i and L_o or L_o , respectively).

Example 1

As certified under IECEx certificate SIR 16.0044X, the Siemens A5E35956261001 IS power barrier has the following entity parameters:

$$U_o = 9.5V \quad I_o = 0.98A \quad P_o = 3.74W \quad C_o = 3.7\mu F \quad L_o = 37\mu H$$

The Siemens barrier can be used as a supply for the main power input, valve inputs, or both. To verify, compare the barrier output entity parameters to the input entity parameters in Table 1 of the Alicat control drawing ([page 10](#)):

- U_o (9.5V) < U_i max of 28V
- P_o (3.75W) is inconsequential, since U_i < 15V thus P_i is internally limited by the Alicat device
- I_o (0.98) < 3.33A stated for the U_o of 9.5V < 12.1V
- $C_i = 0$ thus only C_{cable} is applied to C_o
- $L_i = 0$ thus only L_{cable} is applied to L_o
- No L_o/R_o is stated.

In some cases, a cable may be defined as L/R in units of $\mu H/\Omega$, meaning, simply, the total inductance of a wire divided by the resistance of the wire. In this case, the measurement is independent of length. Some IS device certificates specify the maximum cable L/R that can be connected to their device. This value can be different based upon the gas group, since lesser gas groups are less flammable, i.e., require more energy to ignite, thus allowing a higher inductance.

The user must evaluate the system for every barrier and the associated apparatus.

The parameters apply when one of the two conditions below is given:

- The total L_i of the external circuit (excluding the cable) is < 1% of the L_o value or the total C_i of the external circuit (excluding the cable) is < 1% of the C_o value.

The parameters are reduced to 50% when both of the conditions below are given:

- The total L_i of the external circuit (excluding the cable) > 1% of the L_o and the total C_i of the external circuit (excluding the cable) > 1% of the C_o .

Using the Alicat cable values of $C_{cable} = 550pF/m$ and $L_{cable} = 1.0\mu H/m$, compute the maximum allowed cable lengths:

$$\begin{aligned} C_o &> (C_i + [\text{Cable Length}] \times C_{cable}) \rightarrow \\ 3.7\mu F &> \{0 + [\text{Cable Length}] \times [550pF/m]\} \rightarrow \\ 3.7\mu F / [550pF/m] &> [\text{Cable Length}] \rightarrow \\ 6727m &> [\text{Cable Length}] \end{aligned}$$

$$\begin{aligned} L_o &> (L_i + [\text{Cable Length}] \times L_{cable}) \rightarrow \\ 37\mu H &> (0 + [\text{Cable Length}] \times [1.0\mu H/m]) \rightarrow \\ 37\mu H / [1.0\mu H/m] &> [\text{Cable Length}] \rightarrow \\ 37m &> [\text{Cable Length}] \end{aligned}$$



Note: The maximum cable length for use with the SIEMENS barrier is 37 meters. Since the Alicat L_i and C_i are both 0, multiple Alicat power and valve inputs may be connected in parallel as long as the total cable length in the system is 37 m max.

Example 2

The EATON 9493-PS-C11 can be used with the Alicat Main and/or Valve power inputs.

Type	Gas Group (Zones)	U_o (V)	I_o (A)	P_o (W)	C_o (μ F)	L_o (μ H)	L_o/R_o (μ H/ Ω)
9493-PS-C11	IIC (Acetylene, Carbon Disulphide, Hydrogen)	12	2.25	6.73	1.41	Not provided. Must use Lo/Ro,	5.3
	IIB (Coke Oven Gases, Ethylene)				9		21.1
	IIA (Petrol, Propane, Industrial Methane)				36		42.2
	I [Firedamp (Methane)]				38		69.5

For main power input and valve power input, refer to the Alicat Control Drawing Table 01 ([page 10](#)).

This example is more complicated because there are different entity parameters for each gas group. U_o , P_o , and I_o remain the same:

- U_o (12V) < U_i max of 28V
- P_o (6.73W) is inconsequential, since $U_i < 15V$ thus P_i is internally limited by the Alicat device
- I_o (2.25A) < 3.33A stated for the U_o of 9.5V < 12.1V
- $C_i = 0$ thus only C_{cable} is applied to C_o
- $L_i = 0$ thus only L_{cable} is applied to L_o
- No L_o/R_o is stated for the Alicat device.

Using the Alicat cable values of 550pF/m, 1.0 μ H/m and 5.3 μ H/ Ω , compute the maximum allowed cable lengths:

Gas Group IIC

$$C_o > (C_i + [\text{Cable Length}] \times C_{cable}) \rightarrow$$

$$1.41\mu\text{F} > (0 + [\text{Cable Length}] \times [550\text{pF/m}]) \rightarrow$$

$$1.41\mu\text{F} / [550\text{pF/m}] > [\text{Cable Length}]$$

$$2563\text{m} > [\text{Cable Length}]$$

L_o is not supplied, thus only L/R can be used.

The default value for $L/R = 5.3 \mu\text{H}/\Omega$ is \leq the allowed value of $5.3 \mu\text{H}/\Omega$. This is a length independent parameter!

Based on the capacitance only, the maximum cable length allowed is 2563m.

Gas Group IIB

$$C_o > (C_i + [\text{Cable Length}] \times C_{cable}) \rightarrow$$

$$9\mu\text{F} > (0 + [\text{Cable Length}] \times [550\text{pF/m}]) \rightarrow$$

$$9\mu\text{F} / [550\text{pF/m}] > [\text{Cable Length}] \rightarrow$$

$$16363\text{m} > [\text{Cable Length}]$$

L_o is not supplied, thus only L/R can be used.

The default value for $L/R = 5.3 \mu\text{H}/\Omega$ is $<$ the allowed value of $21.1 \mu\text{H}/\Omega$. This is a length independent parameter!

Based on the capacitance only, the maximum cable length allowed is 16363m.

Gas Group IIA

$$C_o > (C_i + [\text{Cable Length}] \times C_{cable}) \rightarrow$$

$$36\mu\text{F} > (0 + [\text{Cable Length}] \times [550\text{pF/m}]) \rightarrow$$

$$36\mu\text{F} / [550\text{pF/m}] > [\text{Cable Length}] \rightarrow$$

$$65455\text{m} > [\text{Cable Length}]$$

L_o is not supplied, thus only L/R can be used.

The default value for $L/R = 5.3 \mu\text{H}/\Omega$ is $<$ the allowed value of $36 \mu\text{H}/\Omega$. This is a length independent parameter!

Based on the capacitance only, the maximum cable length allowed is 65455m.



Note: The maximum cable length for the Eaton 9493-PS-C11 barrier is limited by the capacitance only. Choosing the shortest length, gas Groups IIA-IIC can be used where the maximum cable length allowed is 2563m.

HAZARDOUS LOCATION
Class I, Zone 0, Group IIC, T4
Class I, Div. 1, Group A,B,C,D,T4
Ta -20°C to +70°C

NON-HAZARDOUS LOCATION OR RATED LOCATION
(Installer must observe barrier manufacturer's instructions, equipment markings and special conditions for all devices)

Alicat IS-Max or IS-Pro

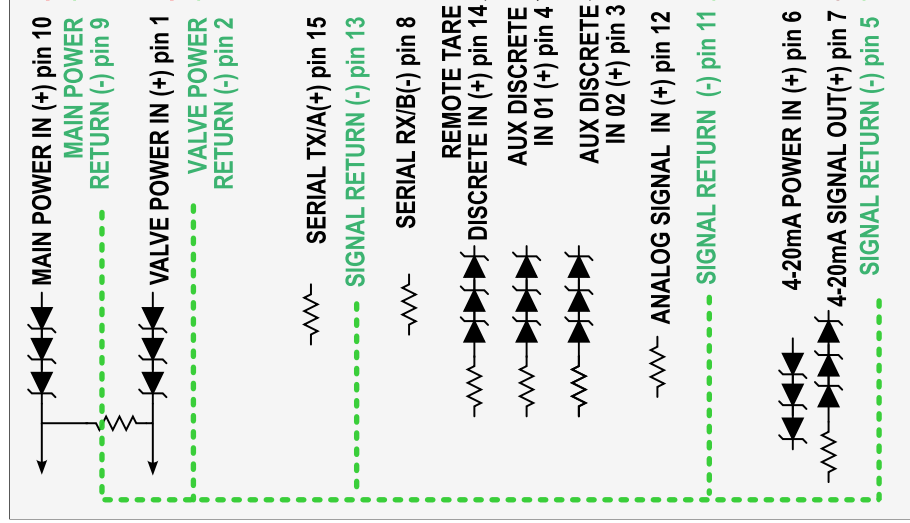

NOTE: ALL POWER AND SIGNAL RETURNS ARE CONNECTED TOGETHER INTERNAL TO DEVICE AND ISOLATED FROM CHASSIS.

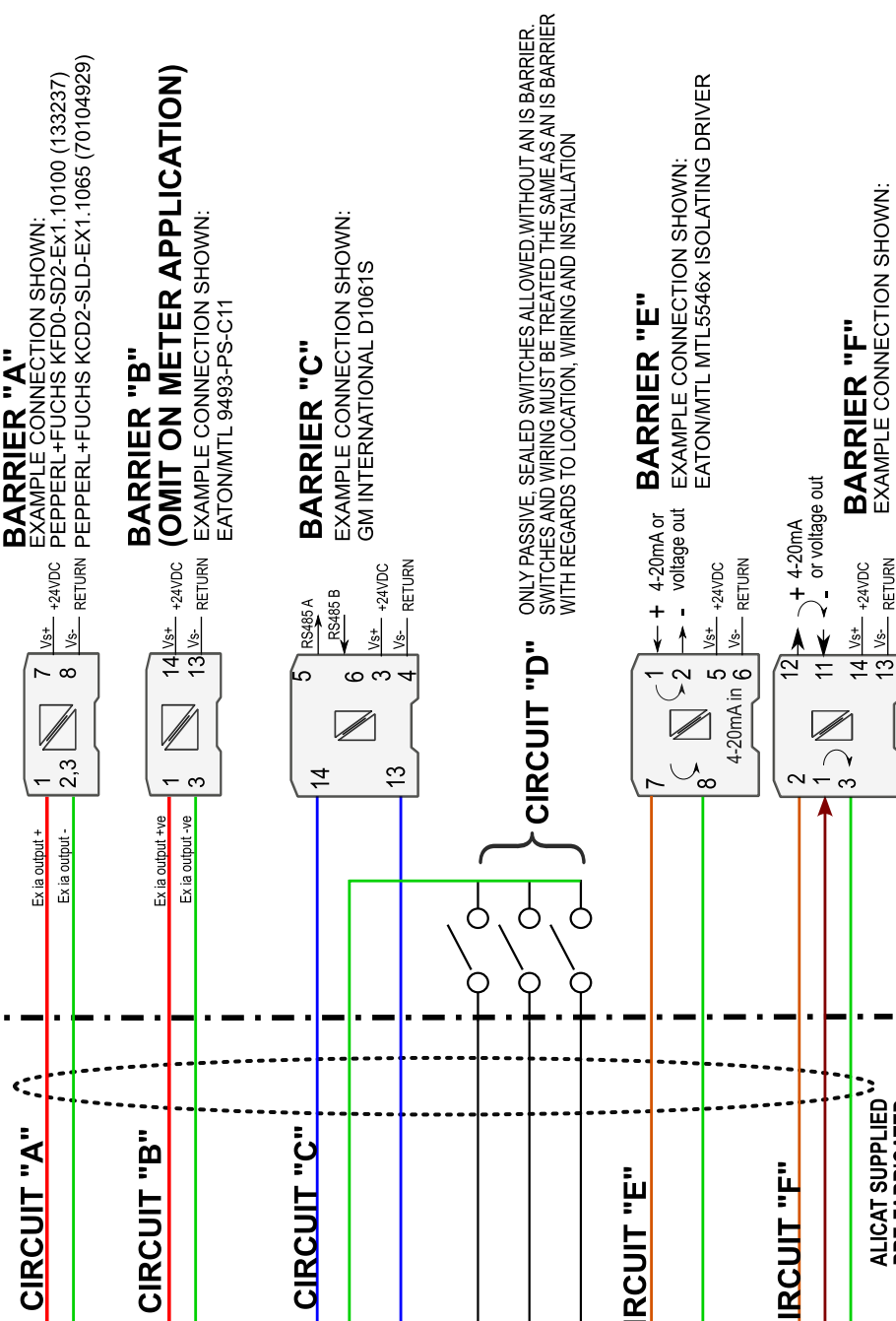

CONFIGURATION 01 - GALVANICALLY ISOLATED SERIAL RS485
(No earth ground required)

HAZARDOUS LOCATION
 Class I, Zone 0, Group IIC, T4
 Class I, Div. 1, Group A,B,C,D,T4
 Ta -20°C to +70°C

NON-HAZARDOUS LOCATION OR RATED LOCATION
 (Installer must observe barrier manufacturer's instructions, equipment markings and special conditions for all devices)

ALICAT IS-Max or IS-Pro

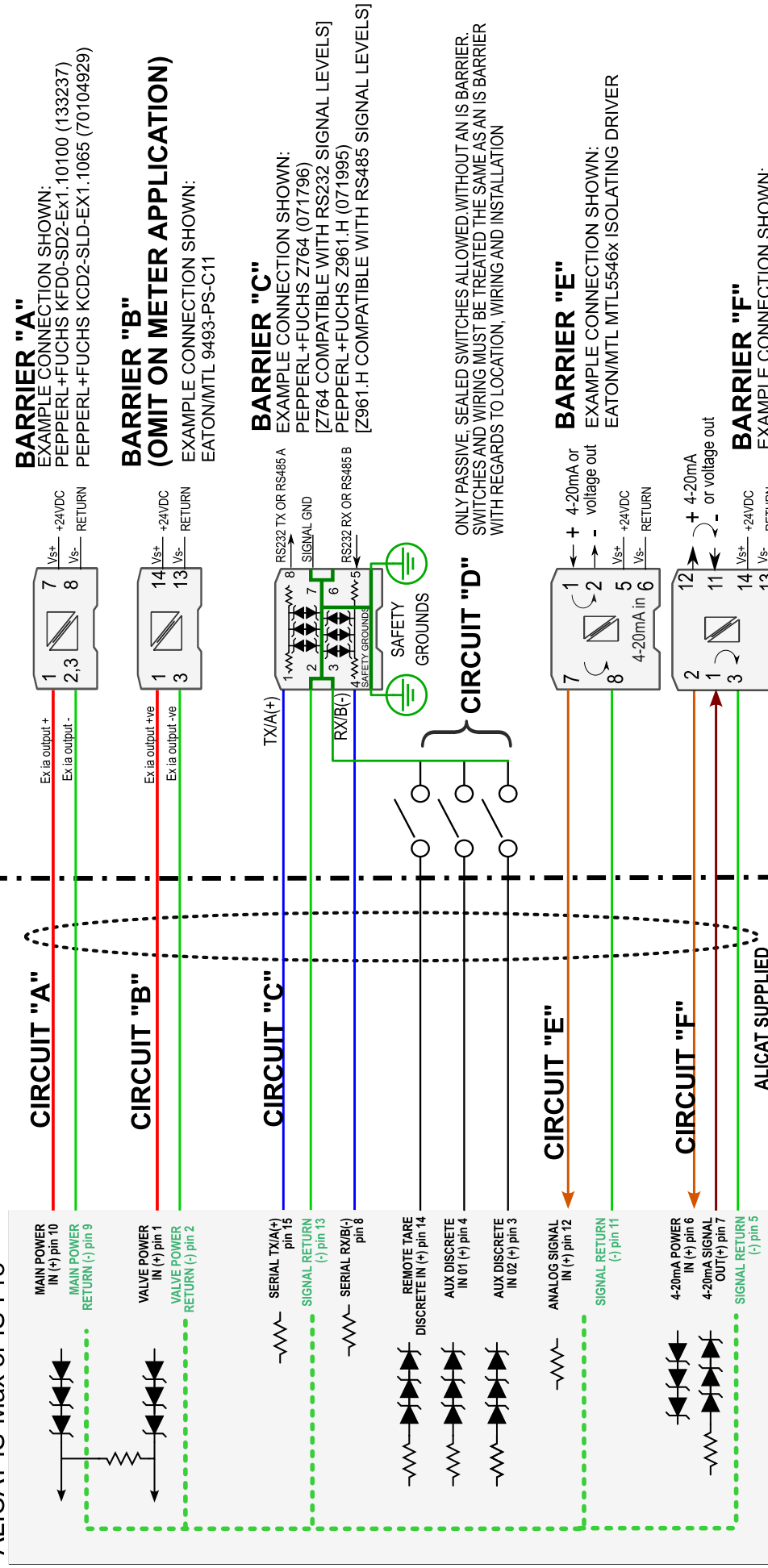

NOTE: ALL POWER AND SIGNAL RETURNS ARE CONNECTED TOGETHER INTERNAL TO DEVICE AND ISOLATED FROM CHASSIS.

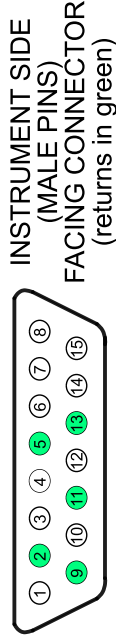

CONFIGURATION 02 - NON-GALVANICALLY ISOLATED SERIAL

Hazardous Area:
 Class I, Zone 0, Group IIC, T4
 Class I, Div. 1, Group A,B,C,D, T4
 Ta -20°C to +70°C

Non-Hazardous Area
 (Installer must observe barrier manufacturer's instructions, equipment markings and special conditions for all devices)

ALICAT IS-Max or IS-Pro

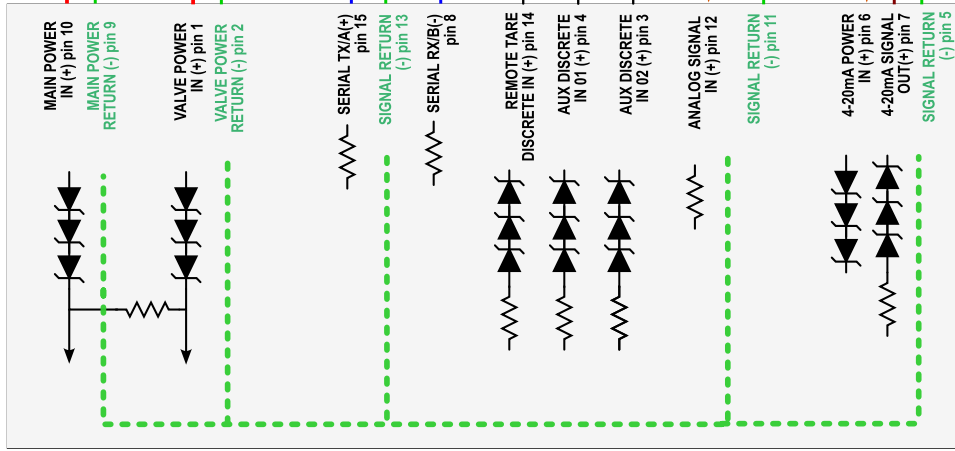

NOTE: ALL POWER AND SIGNAL RETURNS ARE CONNECTED TOGETHER INTERNAL TO DEVICE AND ISOLATED FROM CHASSIS.

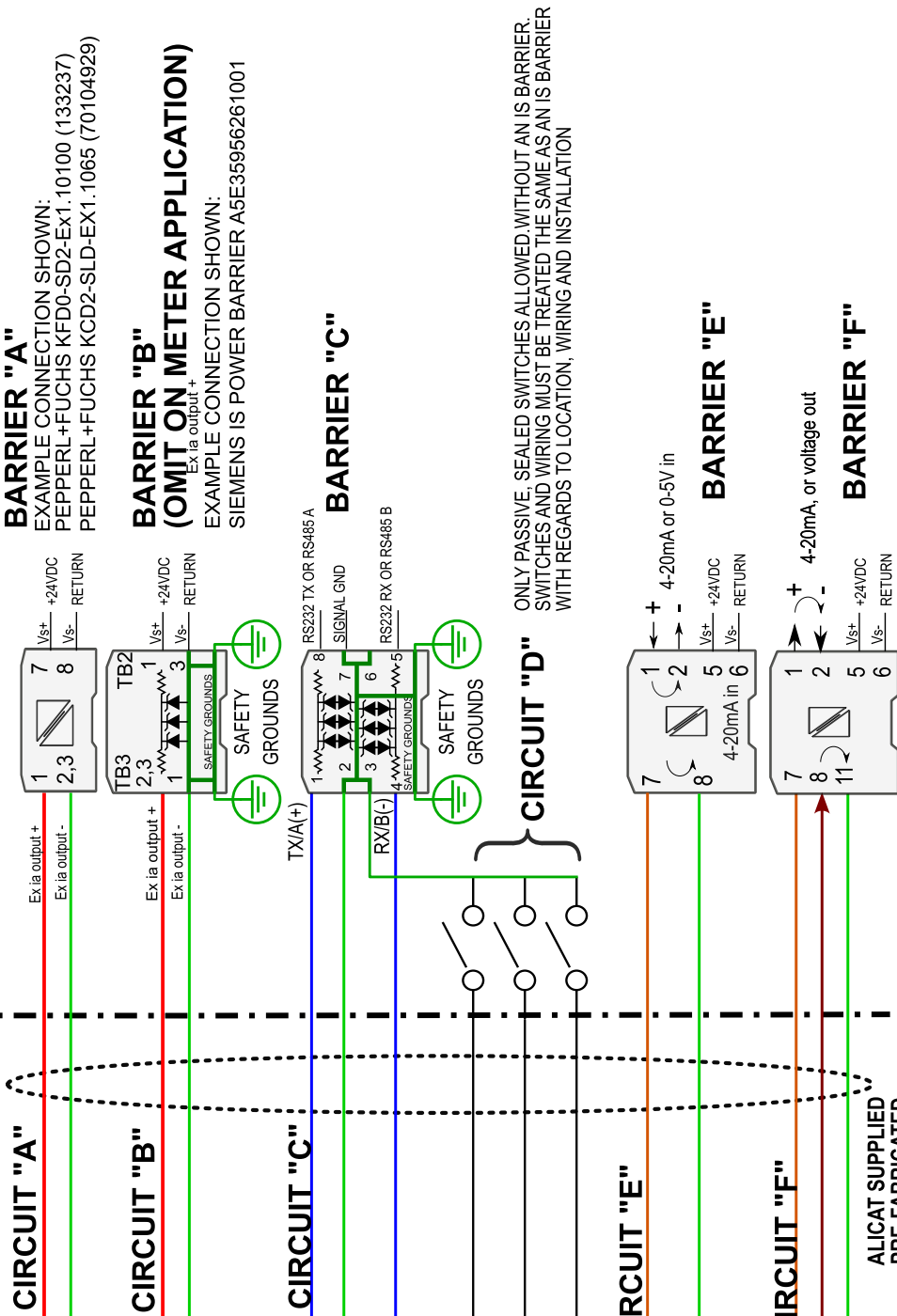

BARRIER "A"

EXAMPLE CONNECTION SHOWN:
 PEPPERL+FUCHS KFD0-SD2-EX1.10100 (133237)
 PEPPERL+FUCHS KCD2-SLD-EX1.1065 (70104929)

BARRIER "B"
 (OMIT ON METER APPLICATION)

EXAMPLE CONNECTION SHOWN:
 SIEMENS IS POWER BARRIER A5E35956261001

BARRIER "C"

CIRCUIT "D"

ONLY PASSIVE, SEALED SWITCHES ALLOWED WITHOUT AN IS BARRIER. SWITCHES AND WIRING MUST BE TREATED THE SAME AS AN IS BARRIER WITH REGARDS TO LOCATION, WIRING AND INSTALLATION

BARRIER "E"

BARRIER "F"

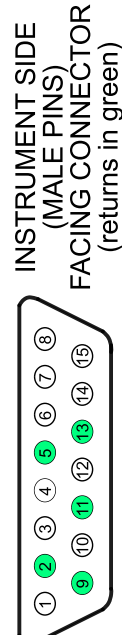

ALICAT SUPPLIED PRE-FABRICATED MOULDED CABLE

CONFIGURATION 03 - NON-GALVANICALLY ISOLATED VALVE BARRIER AND NON-GALVANICALLY ISOLATED SERIAL BARRIER

NOTE: FLOW RANGE MAY BE REDUCED DUE TO LIMITED BARRIER POWER

HAZARDOUS LOCATION
 Class I, Zone 0, Group IIC, T4
 Class I, Div. 1, Group A,B,C,D,T4
 Ta -20°C to +70°C

NON-HAZARDOUS LOCATION OR RATED LOCATION
 (Installer must observe barrier manufacturer's instructions, equipment markings and special conditions for all devices)

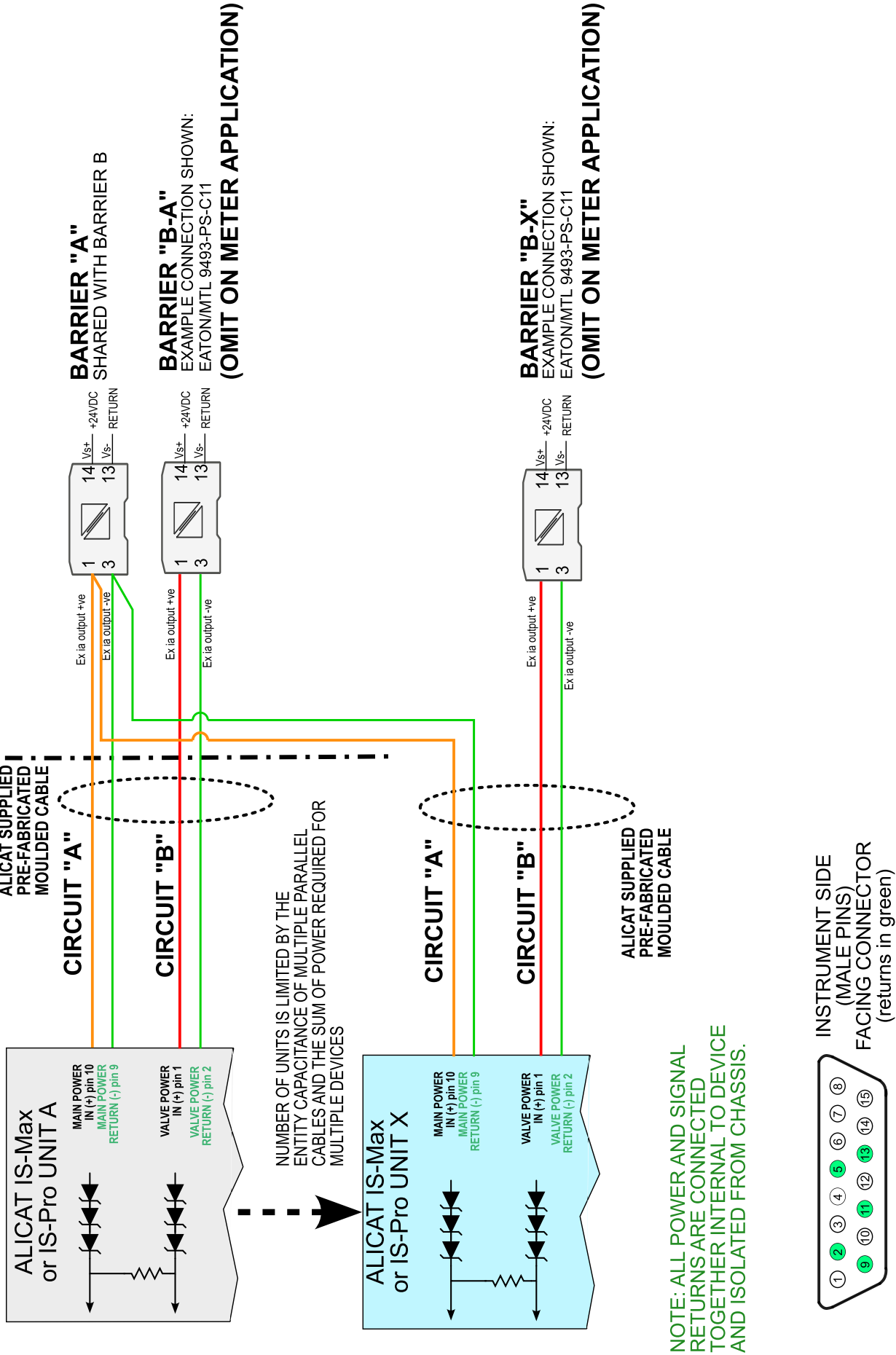

CONFIGURATION 04 - SHARED ISOLATED BARRIER FOR MAIN POWER

HAZARDOUS LOCATION
Class I, Zone 0, Group IIC, T4
Class I, Div. 1, Group A,B,C,D, T4
Ta -20°C to +70°C

NON-HAZARDOUS LOCATION OR RATED LOCATION
(Installer must observe barrier manufacturer's instructions, equipment markings and special conditions for all devices)

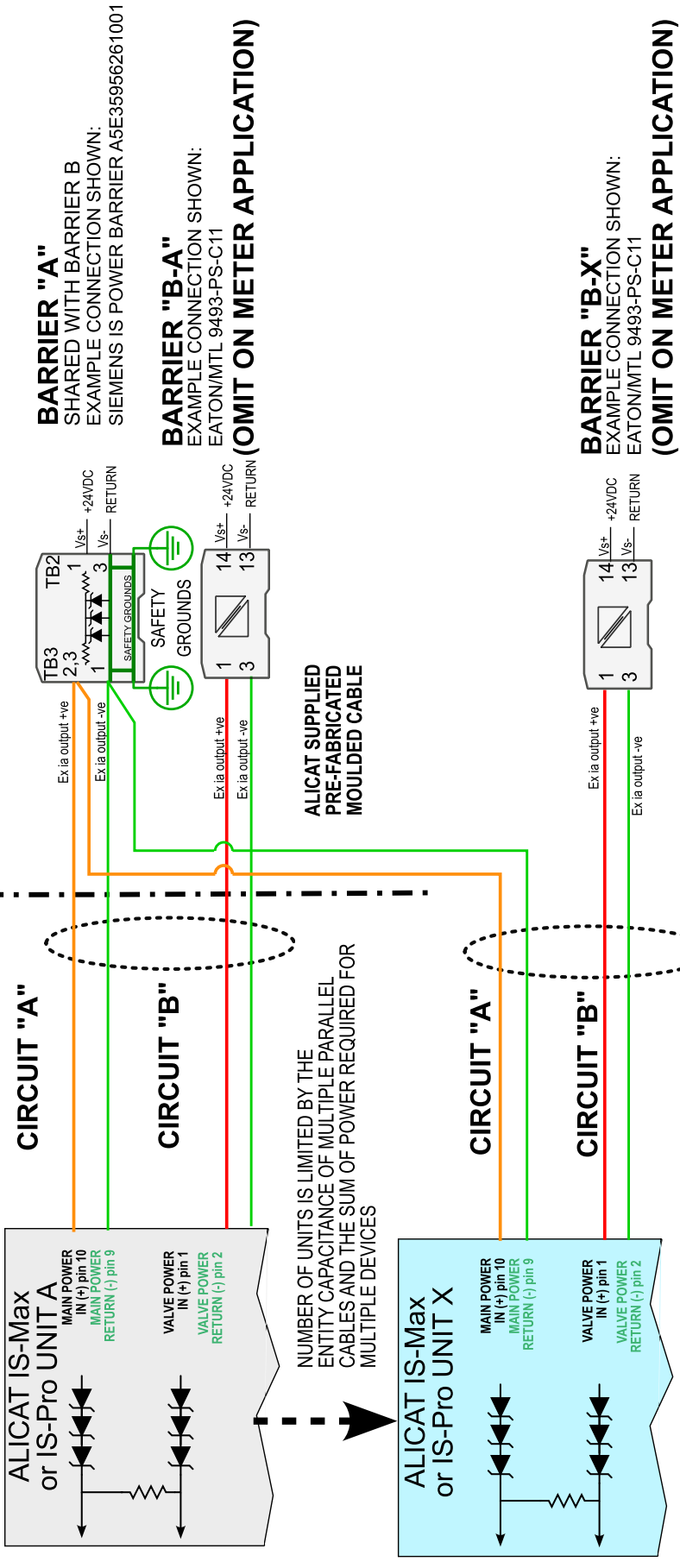

NUMBER OF UNITS IS LIMITED BY THE ENTITY CAPACITANCE OF MULTIPLE PARALLEL CABLES AND THE SUM OF POWER REQUIRED FOR MULTIPLE DEVICES

NOTE: ADDITIONAL NON-ISOLATED BARRIERS MUST BE CO-LOCATED WITH BARRIER A AND MUST UTILIZE THE SAME EARTH GROUND. SEPARATED GROUNDS ARE NOT PERMITTED

ALL PARALLELED ALICAT DEVICES MUST HAVE COMMON GROUNDED MANIFOLDS/PIPING OR BE COMPLETELY GALVANICALLY ISOLATED FROM EACH OTHER AND TO EARTH GROUND (FLOATING)

INSTRUMENT SIDE (MALE PINS) FACING CONNECTOR (returns in green)

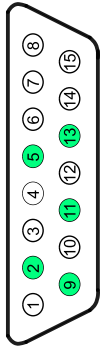

CONFIGURATION 05 - SHARED NON-ISOLATED BARRIER FOR MAIN POWER

HAZARDOUS LOCATION
 Class I, Zone 0, Group IIC, T4
 Class I, Div. 1, Group A,B,C,D,T4
 Ta -20°C to +70°C

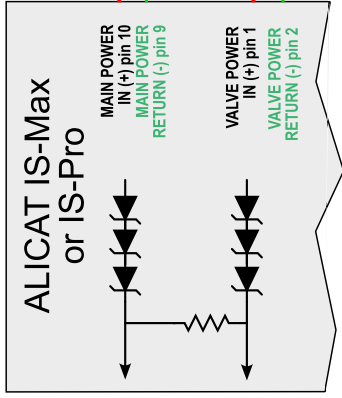

NOTE: ALL POWER AND SIGNAL RETURNS ARE CONNECTED TOGETHER INTERNAL TO DEVICE AND ISOLATED FROM CHASSIS.

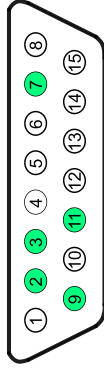

**INSTRUMENT SIDE
 (MALE PINS)
 FACING CONNECTOR**

NON-HAZARDOUS LOCATION OR RATED LOCATION
 (Installer must observe barrier manufacturer's instructions, equipment markings and special conditions for all devices)

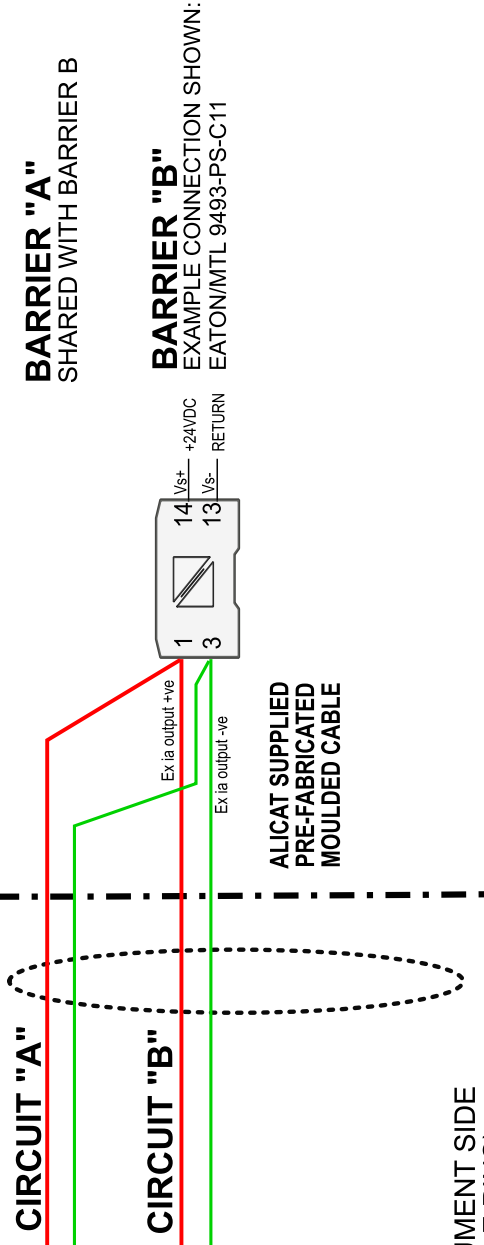

BARRIER "A"
 SHARED WITH BARRIER B

BARRIER "B"
 EXAMPLE CONNECTION SHOWN:
 EATON/MTL 9493-PS-C11

**ALICAT SUPPLIED
 PRE-FABRICATED
 MOULDED CABLE**

CONFIGURATION 06 - SINGLE ISOLATED BARRIER FOR POWER

Cable and Connector Pinout

All IS-Max and IS-Pro intrinsically safe devices are supplied with a cable for power, communication, and analog I/O. Below are the pinouts for both controllers and meters.



Use only Alicat-supplied intrinsically safe cables. Other cables may not maintain the designed circuit isolation or sealing capabilities provided by Alicat cables. Confirm your cable is marked as an Alicat part.

Refer to the previous control drawing for wiring configurations. Consult your barrier's instructions for proper installation.

For more information on communicating with your device via RS-232/485 serial communications or the MODBUS-RTU protocol, please read the **Operations Manual for IS-Max and IS-Pro Intrinsically Safe Devices**. The manual can be found at alicat.com/manuals.

Pinouts

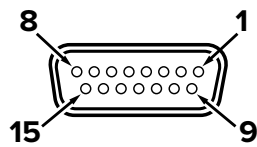

Female Connector

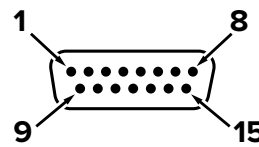

Male Connector

PIN	COLOR	CIRCUIT	CONTROLLER
1	Red [†]	B	Valve power in (+)
2	Brown [†]	B	Valve power return
3	Green	D	AUX discrete in 02 (+)
4	Yellow	D	AUX discrete in 01 (+)
5	Blue	F	4-20mA power/signal return
6	Purple	F	4-20mA power in (+)
7	Gray	F	4-20mA signal out(+)
8	White	C	Serial RX/B
9	Black [‡]	A	Main power return
10	Orange [‡]	A	Main power in (+)
11	Brown/White	E	Analog in signal return
12	Red/White	E	Analog signal in (+)
13	Green/White	C	Serial signal return
14	Blue/White	D	Remote tare discrete (+)
15	Black/White	C	Serial TX/A

PIN	COLOR	CIRCUIT	METER
1	Red [†]	B	Unused
2	Brown [†]	B	Unused
3	Green	D	AUX discrete in 02 (+)
4	Yellow	D	AUX discrete in 01 (+)
5	Blue	F	4-20mA power/signal return
6	Purple	F	4-20mA power in (+)
7	Gray	F	4-20mA signal out(+)
8	White	C	Serial RX/B
9	Black [‡]	A	Main power return
10	Orange [‡]	A	Main power in (+)
11	Brown/White	E	Analog in signal return
12	Red/White	E	Analog signal in (+)
13	Green/White	C	Serial signal return
14	Blue/White	D	Remote tare discrete (+)
15	Black/White	C	Serial TX/A

The maximum cable entity values are 550pF/meter, 1.0μH/meter for individual conductors with respect to return.

[†] *The red and brown conductors are a twisted pair with a defined maximum L/R ratio of 5.3μH/Ω*

[‡] *The orange and black conductors are a twisted pair with a defined maximum L/R ratio of 5.3μH/Ω **

Troubleshooting

If you experience any trouble with installation or operation, please contact Alicat support ([page 2](#)).

General Use

Issue: *My device does not turn on or has trouble staying on.*

Action: Check power and ground connections. Please reference the control drawings and power specifications to ensure you have the proper power for your model.

The device may disable itself or cease to drive the control valve(s) if it exceeds the safe operating thermal parameters. Confirm that the device is operating below the 70°C maximum ambient temperature specification.

Issue: *How often do I need to calibrate my device?*

Action: Annual recalibration is recommended. When it is time to recalibrate, request a recalibration from customer support ([page 2](#)).

Issue: *I dropped my device. Is it OK? Do I need to recalibrate?*

Action: The device has been tested to withstand impacts equivalent to dropping the device onto a hard surface from a height of 30cm/1 foot. If dropped from greater height, inspect the device to verify that there is still a tight fit between the black anodized aluminum upper case and the stainless-steel flow body, and that there are no visible signs of other damage that could compromise the IP rating of the enclosure. Then compare the device against a known good flow standard. If there is any doubt about the device's accuracy or leak integrity, return the device to Alicat for service.

Issue: *Does the device work if it is laying down? Will it be accurate?*

Action: The device is internally compensated for any changes in orientation and can be used sideways, on its back, or upside-down. Devices should be tared after changing orientation. See the **Operations Manual IS-Max and IS-Pro Inherently Safe Devices** for taring instructions. The manual can be found at alicat.com/manuals.

Issue: *Can I put the flow device on top of a vibrating device? Will it be accurate?*

Action: Yes, you can, however sensor noise can increase if the device is vibrating.

Still experiencing issues? Please contact support. See [page 2](#).

Maintenance

Cleaning

Mass flow and **pressure devices** do not require cleaning, if they flow clean, dry gas. Do not flow gas with particulates or debris.

Liquid devices should have filters in place to remove particulates or biological materials that may grow in the device. When removing liquid devices from the line for an extended period of time, remove all liquids to ensure no deposits of calcium or other soluble minerals can affect the device.

All devices may have the outside cleaned with a soft dry cloth, if necessary.



If you suspect that debris or other foreign material has entered your device, do not take apart the flow body to clean it. Contact support for cleaning ([page 2](#)).

Repair

If you find your device has malfunctioned in some way or appears to no longer work as intended, please contact Alicat support to perform maintenance ([page 2](#)). This device may only be serviced by certified Alicat personnel. Any attempt to dismantle and repair the device may void the warranty and may cause further device failure.

Recalibration

The recommended period for recalibration is once every year. A label located on the back of the device lists the most recent calibration date. This date is also stored inside your flow controller and is visible by selecting **MENU** → **ABOUT** → **About Device**. When it is time for your device's annual recalibration, contact support ([page 2](#)) with your device's serial number and your contact information.

