



Automating the Ancient Art of Glass Blowing

A simple and effective way to improve quality and reduce the cost of glass bulb production

Mic Chaudoir, PhD

ALICAT
SCIENTIFIC

Many modern scientific instruments require glass bulb formation as a critical step during their manufacture. The craft of glass blowing dates back to the 1st Century BC and it became widespread during the growth of the Roman Empire. This discovery enabled a revolution in glass production, shrinking production times from about one hour to a few minutes for most core-formed objects (such as bottles and flasks). This reduction in processing time made glass objects affordable for most citizens. It also spawned a glass luxury market where single items could take hundreds of hours to craft. Demonstrations of glass blowing are still a popular staple at renaissance fairs, artisan communities and museums.

One device that requires a properly formed glass bulb is the xenon arc lamp commonly used in many analytical devices. Xenon arc lamps come in a variety of formats, primarily differentiated by associated electronics and glass bulb shapes. The emission spectrum of Xenon is ideal for many applications which require large photon flux in the UV range (250-400 nanometers). Despite the availability of higher power UV LEDs, much higher photon flux can be achieved by utilizing a Xenon arc lamp.



One application that uses Xenon lamp technology is the UV curing of epoxy. This technique is used in the construction of many high tech devices – ranging from smart phones to telescopes. High performance lenses, fiber optic cables, fiber optic arrays and other demanding manufacturing processes utilize epoxies cured by Xenon lamps (to reduce optical strain caused by mechanically mounting optical devices). The power and consistency of UV range light output is critical for this process. Proper shaping of the glass bulbs used in these systems is still carried out using techniques very similar to traditional glass blowing.

Another common application for glass blowing is in the production of sensors, including pH sensors. These sensors require glass encapsulation and a small bulb to contain the final electrical sensor assembly. These bulbs are generally created by glassblowers who are able to process these small, delicate systems. These glassblowers are experts with amazing manual dexterity and many years of experience and professional development. Several electrodes must then be inserted into a perfectly formed glass bulb to create the common electrical pH probe.

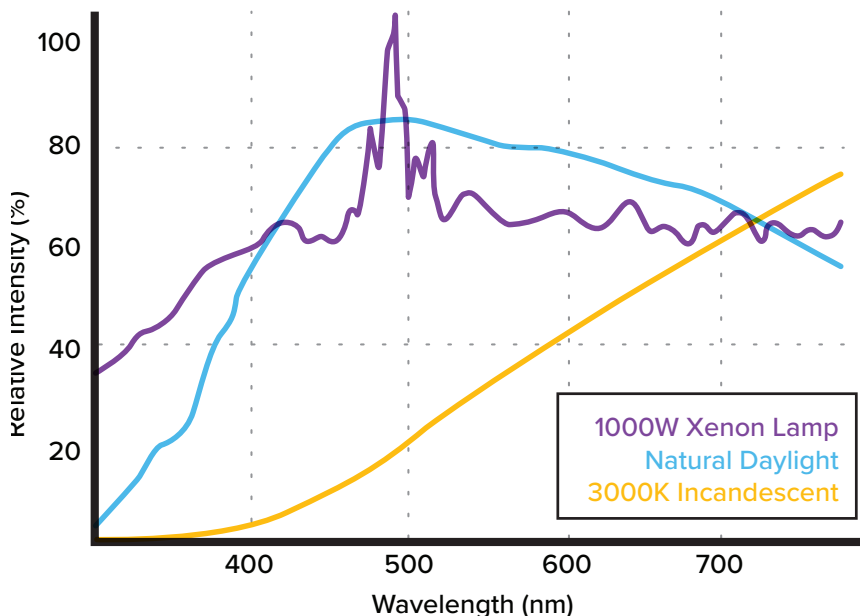

Fig 1: Comparison of emission spectrum of a Xenon arc lamp to incandescent lamps; note the UV region between 300–400nm, where Xenon excels.

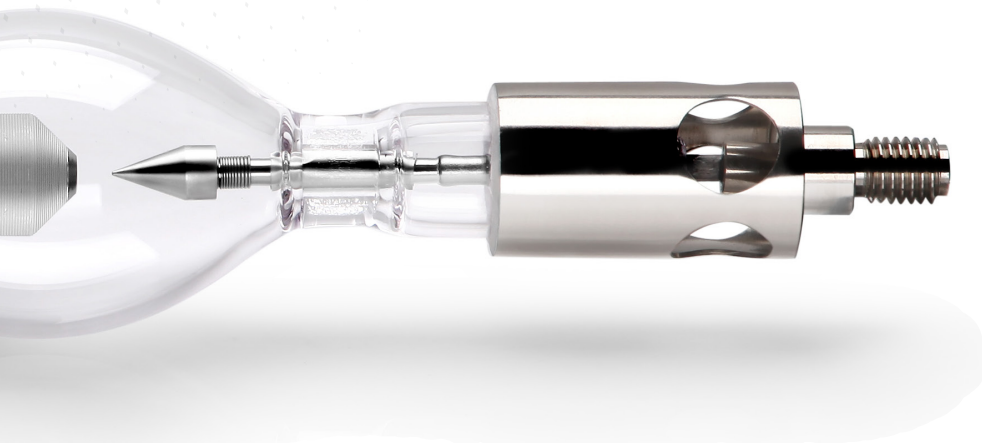

Fig 2: Ushio Xenon lamps. Note the bulb shape and distinctive nub present on the Ushio lamp. ushio.co.jp



Fig 3: The Excelitas Omnicure UV Spot Curing System. excelitas.com

It is now possible to automate this process of pH probe creation utilizing an Alicat mass flow controller in conjunction with off the shelf robotics. As amazing as it may seem, a modern Alicat mass flow controller can regulate the volume of gas delivered even more precisely than an expertly trained pair of lungs! The average adult human holds approximately 6L of air in their lungs under STP conditions. Typical outputs for glassblowing of a small volume can be as little as 10 cc of air expelled over a period of a few seconds. This puts the lower end of the flow range needed for this application at approximately 100 sccm. An Alicat 100 sccm controller can control a range of flow rates from 1 sccm up to 100 sccm with less than 0.1 ccm error. This means that even the smallest volumes can be delivered with volumetric errors of <0.1%. If even greater accuracy at small volumes is required, a 10 sccm controller can create a

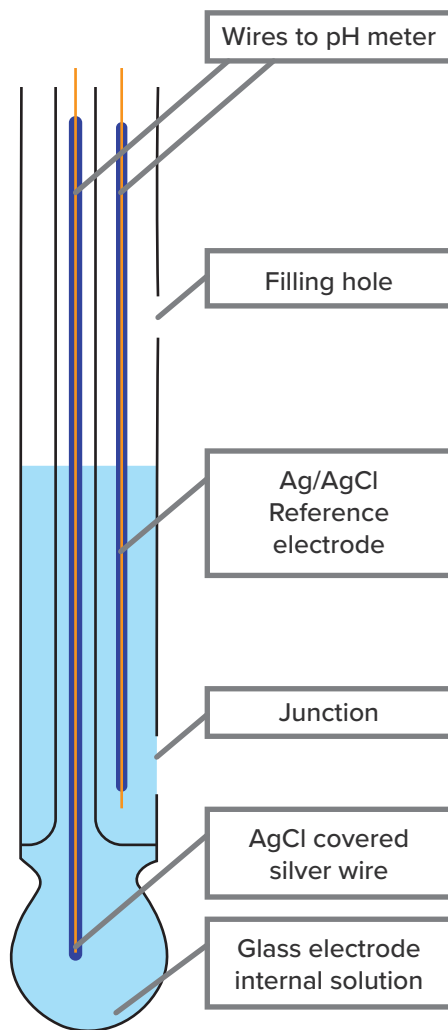

Fig 4: A typical glass pH probe.

1 cc volume with ± 0.01 cc! The very high controllable range of these devices means that one device can accommodate a wide range of volumes – typically a range in excess of 10,000:1. For higher volumes/larger bulbs, even more precision is normally achieved.

Utilizing a mass flow controller to automate glassblowing can add greater accuracy and reliability to this ancient process, while providing the additional benefit of computer control and data logging. Alicat has helped several leading manufacturers automate their process using readily available automation components. If you'd like more information on this process, please contact us. We'd be happy to help improve your glassblowing precision – or any other ancient process you've dug up.

